

Protecta FR Collar - Concrete Wall - Plastic Pipes (PE-LD, PE-MD, PE-HD, PEX, PP, PP-MV, PP-H, PP-R) with Combustible (Elastomeric) or Non-combustible Insulation

Installation Instructions

1. For sealing plastic pipes, a pipe collar is installed on both sides of the wall.
2. Before fitting the pipe collar ensure that any gaps between the pipe and the separating element are sealed. Gaps between the pipe and the construction below 8mm must have a bead of Protecta FR Acrylic to cover the opening, and for gaps 8mm or above, the seal must be plugged with FR Acrylic to a depth of 25mm.
3. Place a pipe collar around the service penetration (pipe) and ensure that the fixing lugs are positioned tightly to the surface of the wall so that the anchors/fixings can be inserted fully.
4. Where the surface is uneven, apply a sealing bead of Protecta® FR Acrylic between the wall and the pipe collar.
5. Attach the pipe collar with masonry screws or expansion bolts that are suitable for the substrate that the collar will be fitted to.
6. On sites where the penetration size is greater than the pipe diameter and/or the pipe is on an angle an oversized collar can be used. Protecta® FR Collars are tested 'oversize', i.e. the internal diameter of the collar can be larger than the pipe.

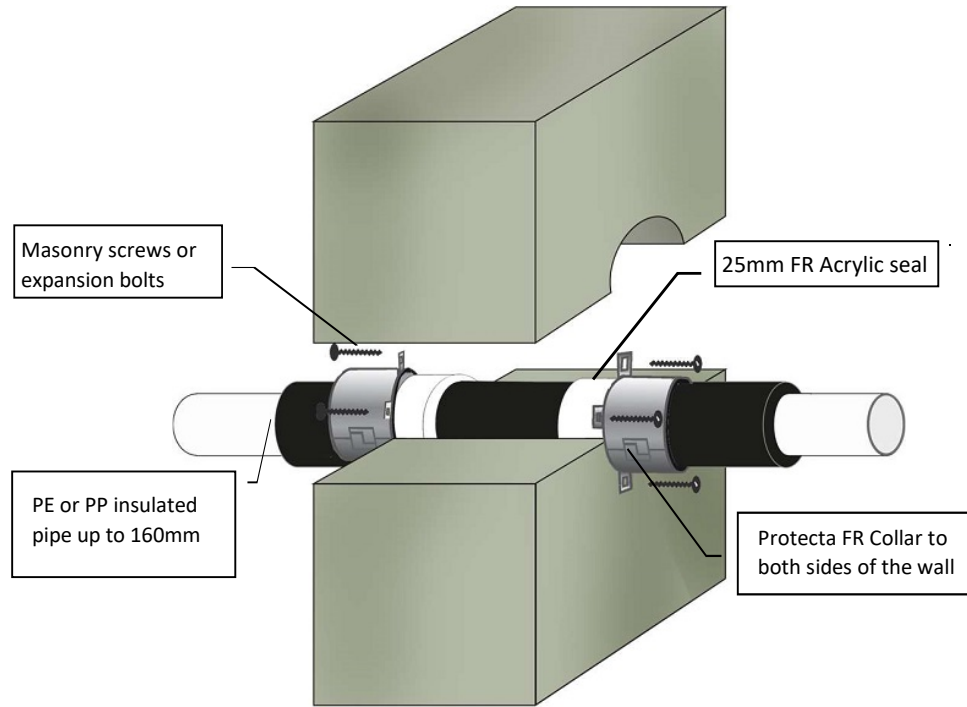

System/FPA Register ID# FC614	
Products	Protecta FR Collar Protecta FR Acrylic
Application	Fire stopping of plastic pipes with combustible or non-combustible insulation in rigid walls.
Construction	Minimum wall thickness of 100mm and comprise concrete, aerated concrete or masonry, with a density of $\geq 650 \text{ kg/m}^3$

Fire & Sound classification	
Pipe may be PE (including PE-LD, PE-MD, PE-HD, PEX) or PP (including PP-MV, PP-H, PP-R) with 9-50mm Elastomeric or non-combustible insulation	
For pipes up to 50mm diam with 50mm FR Collar up to 110mm or 60mm FR Collar up to 200mm	FRR -/90/90
For pipes up to 160mm diam with 75mm FR Collar up to 315mm	FRR -/120/120

ZERO smoke leakage up to 200Pa

As a part of our policy of on-going product development and testing, we reserve the right to modify, alter or change product specifications without giving notice. All information contained in this document is given in good faith and is provided for guidance only. Any drawings provided are for illustrative purposes only. As Polyseam has no control over the methods or competence of installation and of prevailing site conditions, no warranties, expressed or implied, is intended to be given as to the actual performance of the product mentioned or referred to herein and no liability whatsoever will be accepted for any loss, damage or injury arising from the use of the information given.



Sound reduction (seal only) STC 58	
Sheet size: A4	Drawn date & no: 28/7/20
Scale: NTS	Drawn by: K.B